

LCQ-FDIMMER-1CH-30A

Frequency Adjustable Wireless Dimmer



1. Summarization

Frequency adjustable wireless dimmer can achieve ten-level dimming, can dim with button and wireless remote control. User can adjust light to the appropriate brightness according to actual needs. Output of dimmer is 1 channel, and you can adjust PWM frequency and dimming curve through the dial switch.

2. Technical Parameters

Working temperature: -20-60°C

Supply voltage: DC12-24V

Output: 1 channel

Connection mode: common anode

External dimension: L81.5XW64XH40 mm

Packing size: L90XW72XH50 mm

Net weight: 140g

Gross weight: 195g

Static power consumption:<1W

Output current: <30A

(when PWM frequency is more than 1KHZ, maximum output current will reduce accordingly)

Power supply for remote control: 12V

Transmission frequency: 433.92 Mhz

Remote control distance: about 20m

Emission current: 30mA

3. External Dimension

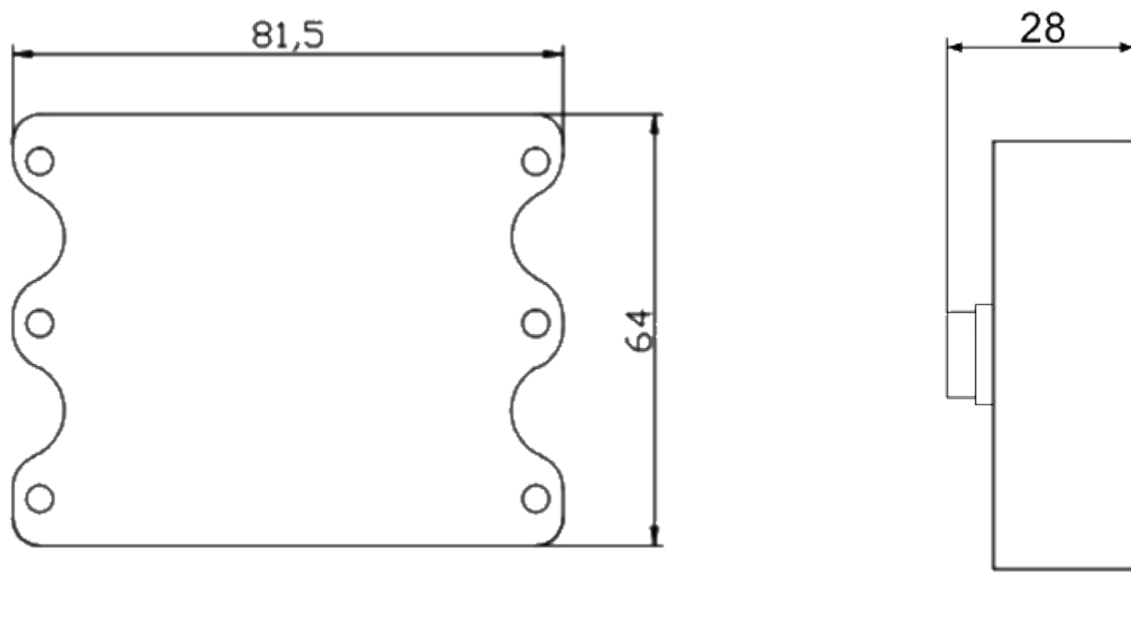

4. Interface introduction

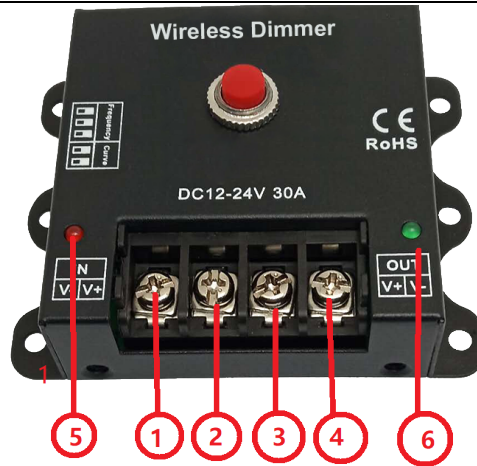

- 1: Power input:V-; 2: Power input:V+; 3: Load output:V+; 4: Load output:V-;
 5: Red light is power indicator; 6: Green light is output indicator;

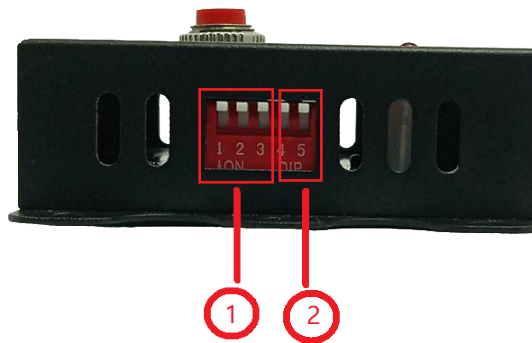

- 1: DIP switch for selecting PWM frequency: 1-3, the PWM frequency is 300 hz
 2: DIP switch for selecting dimming curve: 4-5, Curve to 1 (linear)

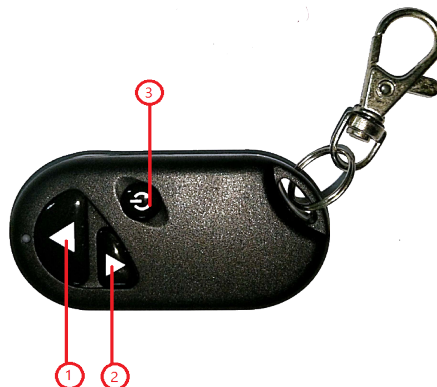

1. brightness+, brightness increases one level each pressing.
2. brightness-, brightness reduces one level each pressing.
3. ON/OFF key, short press to turn on/off light ;

Matching code key: long press this key to match code within 3s after powering on.

5.1 function instruction

5.1.1 select PWM frequency: can output frequency 00HZ/500HZ/700HZ/1KHZ/3KHZ/5KHZ/10KHZ, the output frequency depends on DIP mode, (when dial is 111, output is10KHZ); as below:

Dial code 1	Dial code 2	Dial code 3	PWM
0	0	0	300HZ
1	0	0	500HZ
0	1	0	700HZ
1	1	0	1KHZ
0	0	1	3KHZ
1	0	1	5KHZ
0	1	1	10KHZ

5.1.2 select dimming curve:

Dial code 4	Dial code 5	Curve
0	0	1
1	0	3
0	1	2

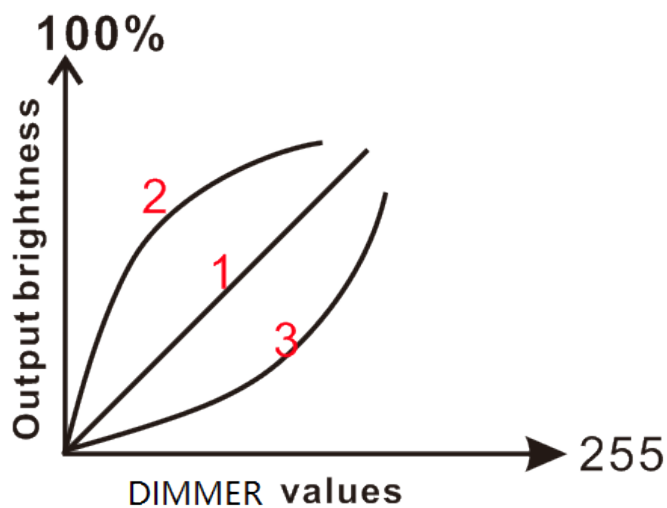

5.1.3 Controller Button Introduction

Long press the button (about 3s) to turn on/off light.

Short press to dim, brightness increases each pressing, total 10 levels. When reach the maximum brightness, press the button again to increase from the lowest brightness.

5.1.4 Remote control matching code description

Long press ON/OFF key of remote control to match code within 3s after powering on. The light will flash

5 times to indicate matching code successfully. One dimmer can be controlled by 2 remote controls.

5.2 Instruction of wiring

Connect the load wire at first, following by the power wire; Please ensure short circuit can not occur between connecting wire before you turn on the power;

6. Typical application

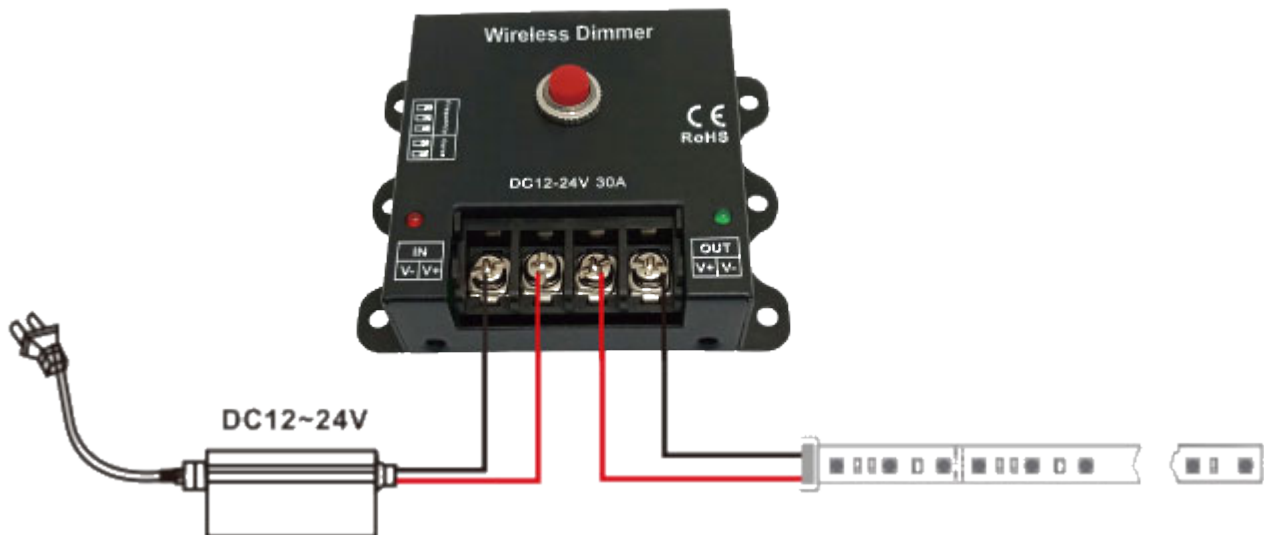

7. Installation Method

Connect corresponding lines according to the interface instruction, note that the line can not be reversed;

8. Remarks

8.1 Connect the load wire at first, following by the power wire; Please ensure short circuit can not occur between connecting wire before you turn on the power;

8.2 When PWM frequency is 300HZ, and maximum load is 30A, the temperature of controller is less than 55°C; When PWM frequency is between 500HZ to 1000HZ, the temperature of controller is less than 65°C;

8.3 When PWM frequency is more than 1KHZ, the maximum output power is reduced. PWM frequency is 3KHZ, the maximum current is 20A; PWM frequency is 5KHZ, the maximum current is 15A; PWM frequency is 10KHZ, the maximum current is 10A.